

COUNTERSINK

Deburring
Chamfering
Countersinking

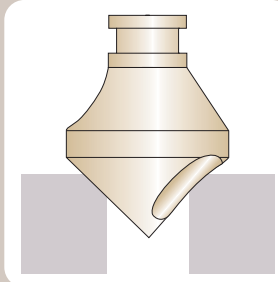

DEBURRING TOOL With Hole

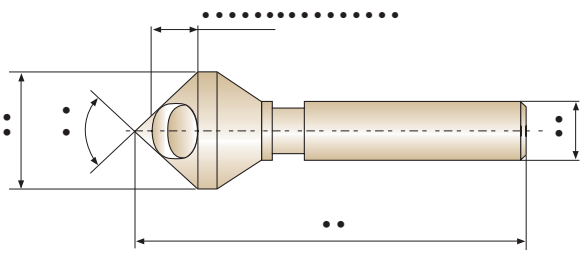

- » For light metals and plastics.
- » For deburring and small chamfers.
- » Best surface finish.
- » Works without vibrations.

Tolerance			
D	α	d	L
+0.3	-1°	h9	±1

unit : mm

Angle	Nominal Diameter	Shank Diameter	Over All Length	Capacity	EDP No. (uncoating)		
α	D	d	L	min/max	M42	M35	M2
90°	10.0	6.0	45.0	2 ~ 5	C1109100	C2109100	C3109100
	15.0	8.0	55.0	6 ~ 14	C1109150	C2109150	C3109150
	20.0	10.0	65.0	8 ~ 18	C1109200	C2109200	C3109200
	25.0	12.0	78.0	10 ~ 23	C1109250	C2109250	C3109250
	30.0	12.0	88.0	12 ~ 28	C1109300	C2109300	C3109300
	35.0	16.0	110.0	14 ~ 33	C1109350	C2109350	C3109350
	40.0	16.0	115.0	16 ~ 38	C1109400	C2109400	C3109400
	45.0	16.0	120.0	18 ~ 43	C1109450	C2109450	C3109450
	50.0	16.0	130.0	20 ~ 48	C1109500	C2109500	C3109500

TiN & TiCN coating is available on your request.

Single flute CHAMFERING CUTTERS

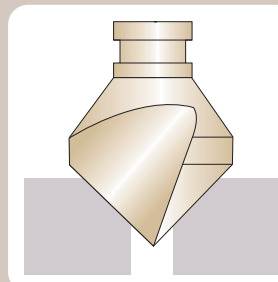
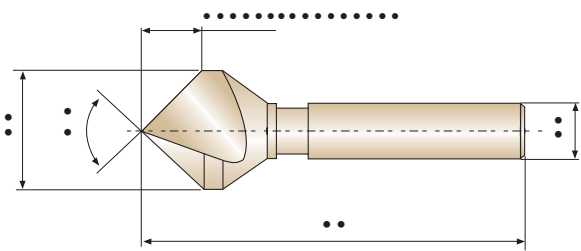

- » For wood and hard plastics.
- » Can drill sheet materials.
- » Easily resharpened.
- » Working completely chatterless.

Tolerance			
D	α	d	L
+0.3	-1°	h9	±1

unit : mm

Angle	Nominal Diameter	Shank Diameter	Over All Length	Capacity	EDP No. (uncoating)		
α	D	d	L	min/max	M42	M35	M2
90°	10.0	6.0	45.0	1 ~ 10	C1119100	C2119100	C3119100
	15.0	8.0	55.0	2 ~ 15	C1119150	C2119150	C3119150
	20.0	10.0	65.0	2 ~ 20	C1119200	C2119200	C3119200
	25.0	12.0	78.0	3 ~ 25	C1119250	C2119250	C3119250
	30.0	12.0	88.0	3 ~ 30	C1119300	C2119300	C3119300
	35.0	16.0	110.0	4 ~ 35	C1119350	C2119350	C3119350
	40.0	16.0	115.0	5 ~ 40	C1119400	C2119400	C3119400
	45.0	16.0	120.0	10 ~ 45	C1119450	C2119450	C3119450
	50.0	16.0	130.0	12 ~ 50	C1119500	C2119500	C3119500

TiN & TiCN coating is available on your request.

Three flutes COUNTERSINKS

- » Self-centering(3 flutes).
- » Designed for 90° capscrews countersinking.
- » Used by Hand.
- » For vertical & slope chamfering.
- » Works without vibrations.

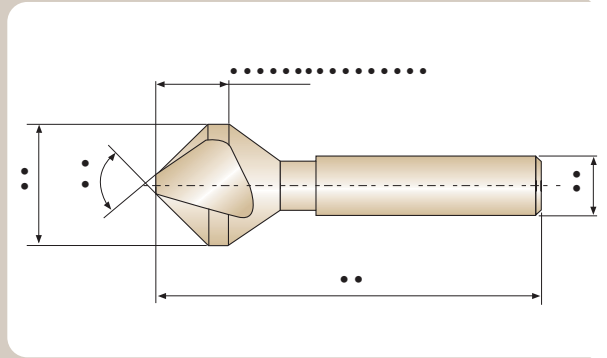
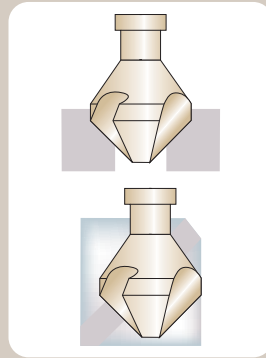

Tolerance			
D	α	d	L
±0.05	-1°	h9	±1

unit : mm

Angle	Nominal Diameter	Shank Diameter	Over All Length	Capacity	EDP No. (uncoating)		
					M42	M35	M2
α	D	d	L	min/max			
90°	10.0	6.0	50.0	2.5 - 10	C1139100	C2139100	C3139100
	15.0	10.0	60.0	3.2 - 15	C1139150	C2139150	C3139150
	20.5	10.0	63.0	3.5 - 20.5	C1139205	C2139205	C3139205
	25.0	10.0	67.0	3.8 - 25	C1139250	C2139250	C3139250
	30.0	12.0	71.0	4.2 - 30	C1139300	C2139300	C3139300
	35.0	16.0	110.0	4.5 - 35	C1139350	C2139350	C3139350
	40.0	16.0	115.0	4.5 - 40	C1139400	C2139400	C3139400
	45.0	16.0	120.0	5.0 - 45	C1139450	C2139450	C3139450
	50.0	16.0	130.0	5.0 - 50	C1139500	C2139500	C3139500

TiN & TiCN coating is available on your request.

RECOMMENDED CUTTING SPEED

V : Cutting Speed
S : Feed per Revolution

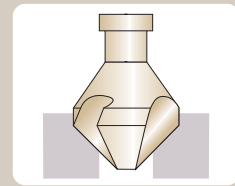
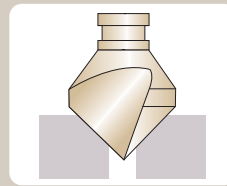
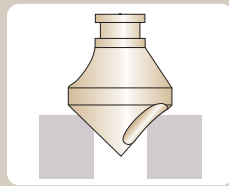

Material	V (mm/min)	S (mm/rev)			V (mm/min)	S (mm/rev)			V (mm/min)	S (mm/rev)		
		$\phi \leq 10$	$\phi \leq 20$	$\phi \leq 30$		$\phi \leq 10$	$\phi \leq 20$	$\phi \leq 30$		$\phi \leq 10$	$\phi \leq 20$	$\phi \leq 30$
Steels $\leq 500N/mm^2$	35~45	0.20	0.22	0.24	35~45	0.20	0.22	0.24	17~22	0.30	0.32	0.36
Steels 500~800N/mm ²	20~30	0.14	0.17	0.20	20~30	0.14	0.17	0.20	10~15	0.28	0.30	0.31
Steels 800~1000N/mm ²	15~20	0.11	0.12	0.14	15~20	0.11	0.12	0.14	8~12	0.24	0.26	0.28
Steels-Stainless Steel 1000~1300N/mm ²	12~15	0.10	0.12	0.15	12~15	0.10	0.12	0.15	6~8	0.20	0.20	0.22
Stainless Steels	6~8	0.07	0.08	0.09	6~8	0.07	0.08	0.09	4~6	0.08	0.09	0.10
Cast Iron	20~40	0.15	0.24	0.28	20~40	0.15	0.24	0.28	15~25	0.13	0.19	0.24
Aluminium	50~60	0.22	0.25	0.27	50~60	0.22	0.25	0.27	35~45	0.27	0.30	0.35
Brass-Bronze	30~40	0.23	0.25	0.28	30~40	0.23	0.25	0.28	20~30	0.30	0.30	0.31
Copper	20~30	0.22	0.25	0.27	20~30	0.22	0.25	0.27	10~15	0.29	0.30	0.31
Plastics	50~100	0.50	0.60	0.65	50~100	0.50	0.60	0.65	35~70	0.40	0.45	0.50

TiN & TiCN coating is available on your request.

◆DISTRIBUTED BY◆



 **YG-1 CO., LTD.**

HEAD OFFICE

68, CHONGCHON-DONG, BUPYEONG-GU, INCHEON, 403-030, KOREA

PHONE : +82-32-526-0909, FAX : +82-32-526-4373

[http : //www.yg1.kr](http://www.yg1.kr)